

CMF01

Crossarm mounting fixture for pyranometers, albedometers and net radiometers

Hukseflux offers a full range of practical brackets for mounting atmospheric radiation sensors in all climates and weather conditions. CMF01 is a versatile fixture allowing mounting a crossarm onto a vertical mast. It is typically used with SR05, SR15 and SR30 pyranometers with their mounting fixtures. It can also be used in combination with NR01 net radiometers, SRA series albedometers and with PMF01.

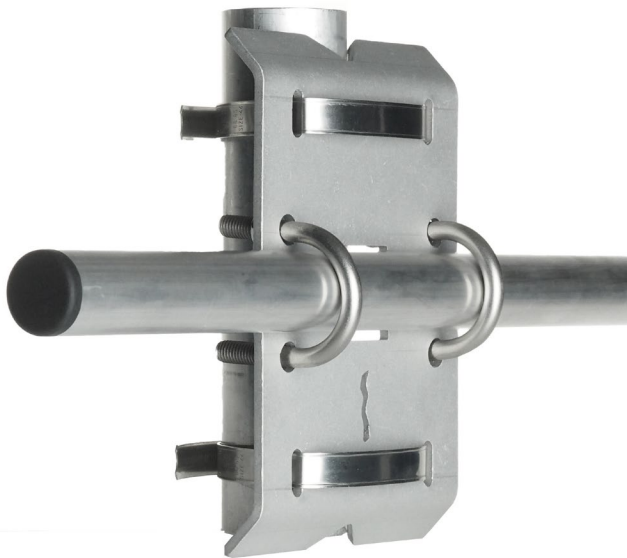

Figure 1 CMF01 crossarm mounting fixture, shown with a crossarm mounted on a mast.



Figure 2 A crossarm can be used for easy installation of a pyranometer, in this case SR30, in Plane of Array, horizontal or inverted for PV system performance monitoring.

Introduction

CMF01 is a practical mounting fixture for mounting a crossarm. The purpose of the crossarm is to mount radiometers on a mast. The crossarm may serve to mount multiple instruments. The crossarm also creates some distance between radiometer and mast, so that the mast does not cast a shadow and does not reflect radiation onto the instrument. A typical distance between mast and radiometer is 1.5 m.

Most crossarms used in radiometry are mounted in the north-south direction so that the radiometer can be mounted towards the equator and a mast extending above the crossarm does not cast a shadow on the instrument.

In PV monitoring we also see crossarms oriented in the east-west direction to mount instruments for Global Horizontal Irradiance (GHI), Plane of Array Irradiance (POA) and Reflected Horizontal Irradiance (RHI).

Advantages

- quick installation
- strong mast-to-crossarm connection
- can carry multiple instruments

Suggested use

- meteorological observations
- PV monitoring

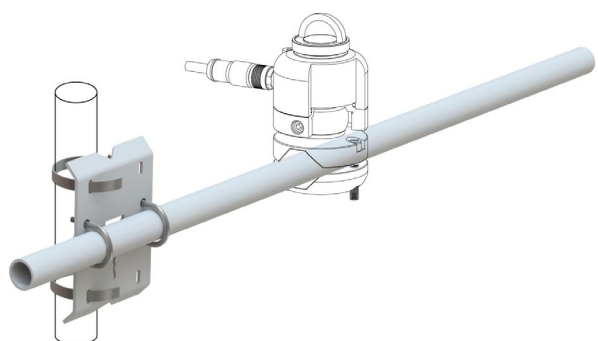

Figure 3 Easy-to-use instructions in CMF01's user manual.

CMF01 design

CMF01 is made of high-quality metals, allowing installations in all climates and weather conditions. It is delivered with u-bolts and tube clamps. The user should provide his own crossarm and instrument(s). The latter can be ordered separately at Hukseflux.



Figure 4 An albedometer being installed with its rod mounted securely to a mast thanks to ALF01 levelling fixture and CMF01 crossarm mounting fixture.

Complementary mounting options

There are other Hukseflux mounting options available for SR30, SR15 and SR05 pyranometers. They allow for simplified mounting, levelling and instrument exchange on a flat surface or a tube, such as a crossarm. These mounts are optional with the purchase of these instruments. Alternatively, PMF01 and PMF02 brackets may be used for mounting any Hukseflux pyranometer on a mast, crossarm or other mounting platform.



Figure 5 Complementary mounting options.

CMF01 specifications

Mast compatibility	diameter (40 to 65) x 10 ⁻³ m
Crossarm compatibility	1 inch pipe length < 1.5 m
Maximum weight on CMF01 (at length of 1.5 m)	2.5 kg

See also

- **SR30** and **SR15** pyranometers with spring-loaded and tube levelling mount
- **SR05** Class C with ball levelling and tube mount
- **SRA15 series** albedometers
- **ALF01** albedometer mounting fixture
- **NR01** net radiometer
- **PMF01** and **PMF02** pyranometer mounting fixtures
- view our complete **range of atmospheric radiation sensors**

About Hukseflux

Hukseflux is the leading expert in measurement of energy transfer. We design and manufacture sensors and measuring systems that support the energy transition. We are market leaders in solar radiation- and heat flux measurement. Customers are served through the main office in the Netherlands, and locally owned representations in the USA, Brazil, India, China, Southeast Asia and Japan.

Interested in this product?
E-mail us at: info@hukseflux.com