

SHR02

Shadow ring for pyranometers – combined with a pyranometer forming a diffusometer

SHR02 is a shadow ring, used in combination with a pyranometer to form a "diffusometer". The ring will prevent direct radiation from reaching the pyranometer from sunrise to sunset, so that the shaded pyranometer measures diffuse radiation only. SHR02 is used with Hukseflux pyranometers such as SR30, SR25 and SR20. These models have very low zero offsets, leading to higher accuracy diffuse measurements than attained with competing models.



Figure 1 SHR02 shadow ring for pyranometers (a pyranometer is not included in SHR02 delivery).



Figure 2 Installation of the compact SHR02 shadow ring and a Hukseflux pyranometer is easy. When combined, a diffusometer is created, in which the shaded pyranometer measures diffuse radiation only.

Introduction

SHR02 is a practical metal shadow ring that helps making diffuse solar irradiance measurements with pyranometers. The shadow ring, also known as a shadow band, prevents direct radiation from reaching the pyranometer. The combination of a shadow ring and a pyranometer is called a diffusometer by the ISO 9060:2018 standard. The compact SHR02, combined with a Hukseflux pyranometer, has several advantages over competing models.

SHR02 is compatible with most Hukseflux pyranometers. Hukseflux pyranometers have very low zero offsets, so that the diffuse radiation measurement has a better uncertainty than that of competing pyranometer-shadow ring diffusometers. To avoid problems with dew and frost deposition, the user should consider using the heated SR25 or the heated and ventilated SR30 pyranometer.

A diffuse horizontal irradiance (DHI) measurement with a pyranometer-shadow ring diffusometer is usually combined with a pyranometer-without a shadow ring. The latter measures the Global Horizontal Irradiance (GHI). Combining GHI and DHI with local solar position, the Direct Normal Irradiance (DNI) can be estimated. Most shadow rings are used with the pyranometer mounted horizontally. The incorporated tilt adjustment stage enables the diffuse irradiance to be measured in a tilted plane. To correct for the changing altitude of the sun, the height of the ring is adjusted manually by adjusting the sliding bars.

Advantages of SHR02

- relatively small size / light weight
- low-investment alternative for a sun tracker with shading-disc
- high accuracy when used with Hukseflux (low zero-offset) pyranometers
- save costs on expensive external ventilation; compatible with SR30 with internal ventilation

Suggested use

- meteorological observations
- building energy performance
- solar energy studies

Setup and accuracy

The altitude of the sun varies throughout the year and this influences the shadow cast by the shadow ring. Aside from adjusting the shadow ring on a regular basis to compensate for this, it should be taken into account that part of the diffuse radiation obscured by the shadow ring will change. Hukseflux provides a specifically tuned model that will aid the user in setting up the SHR02 without the need for in-depth knowledge of diffusometers. In the SHR02 manual a set-up table with required correction factors for the measured diffuse radiation is provided, for a range of latitudes and declinations. The manual also provides theory for creating individual models when higher accuracy is required.

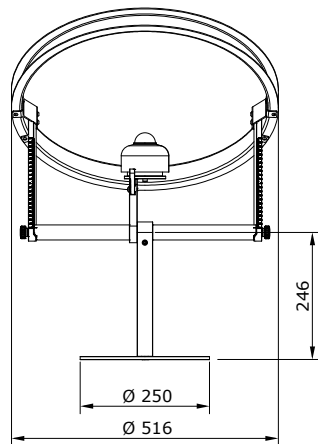
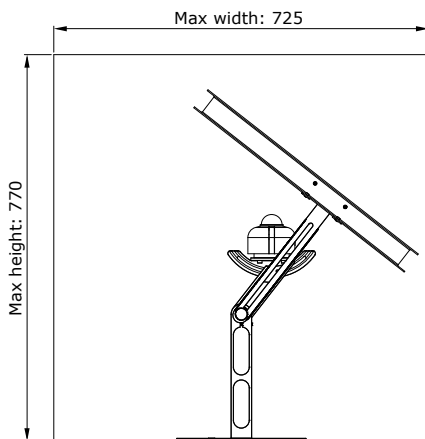

Figure 3 SHR02 dimensions in $\times 10^{-3}$ m.

Compatible pyranometers

SR15, SR30 pyranometers. With mounting adapter also models SR20, SR22 and SR25.

SHR02 specifications

Function	forming a diffusometer when combined with a pyranometer
Diffusometer measurand	diffuse solar radiation in W/m^2
Instrument compatibility	SR30, SR15 pyranometers (recommended)
Instrument compatibility	SR25, SR22, SR20 pyranometers (with optional mounting adapter)
Diffusometer zero offset a	with SR30: 2 W/m^2 with SR15: 5 W/m^2 with SR25: 1 W/m^2 with SR20: 5 W/m^2
Use with heating	with SR30 and SR25
Use with ventilation	with SR30
Ring inner diameter	476×10^{-3} m
Ring profile	U-profile
Weight	3.75 kg
Ring width/radius ratio	0.185
Field of view angle	10.6°
Material	anodised aluminium
Rated operating temperature range	-40 to $+80^\circ C$
Pyranometer tilt angle range	-90 to 90°
Bubble level	included
Levelling screws	included
Required adjustment interval	according to adjustment table
Application of correction factors	user responsibility

Options

Mounting adapter for SR20, SR22 and SR25

See also

- preferred pyranometers [SR30](#) and [SR15](#)

About Hukseflux

Hukseflux is the leading expert in measurement of energy transfer. We design and manufacture sensors and measuring systems that support the energy transition. We are market leaders in solar radiation- and heat flux measurement. Customers are served through the main office in the Netherlands, and locally owned representations in the USA, Brazil, India, China, Southeast Asia and Japan.

Interested in this product?
E-mail us at: info@hukseflux.com