

SR20

Analogue Class A pyranometer

SR20 is a solar radiation sensor of the highest category in the ISO 9060 classification system: spectrally flat Class A. SR20 pyranometer should be used where the highest measurement accuracy is required. It is often used with dataloggers that can directly accept its analog voltage output.



Figure 1 SR20 spectrally flat Class A pyranometer.



Figure 2 Dual setup in PV system performance monitoring.

Introduction

SR20 measures the solar radiation received by a plane surface, in W/m^2 , from a 180° field of view angle. SR20 enables you to attain the highest measurement accuracy at the best value for money and excels in demanding applications. After a thorough programme of acceptance testing, SR20 spectrally flat Class A was released in February 2013; it is now a household name.

Improved measurement accuracy

In order to improve overall measurement accuracy, Hukseflux effectively targeted two major sources of measurement uncertainty: calibration and "zero offset a".

The initial calibration uncertainty is reduced to less than 1.2 %. The "zero offset a" specification of SR20 is $< 5 W/m^2$ unventilated. Ventilated (with **VU01**) it is just $2.5 W/m^2$.

Lowest total cost of ownership

Customers prefer Hukseflux pyranometers for their unsurpassed measurement accuracy and their lowest total cost of ownership. Total costs are mainly determined by costs of installation, on-site inspections, servicing and calibration:

Pyranometers must be calibrated every 2 years. Such recalibration is considered good practice for any measuring instrument and is required by ISO, IEC and WMO standards covering PV system performance – and meteorological monitoring. Cost of recalibration however can be high. Hukseflux' worldwide calibration network will help you reduce these costs. Learn more about Hukseflux [pyranometer calibration services](#).

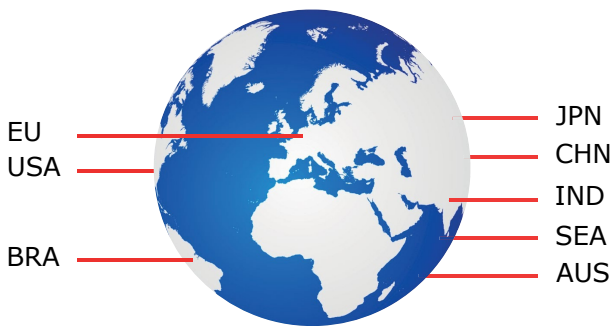

Figure 3 To reduce total cost of ownership: make use of the worldwide Hukseflux calibration organisation.

Demanding applications

SR20's low temperature response makes it an ideal candidate for use under very cold and very hot conditions.

The temperature response of every individual instrument is tested and supplied as a second degree polynomial. This information can be used for further reduction of temperature dependence during post-processing.

The incorporated heater can be used to reduce measurement errors caused by early-morning dew and frost deposition.

Compliant with IEC 61724-1:2021, Class A

SR20 complies, without the need for additional accessories, with IEC requirements. It includes heating for dew and frost mitigation.

SR20 design

SR20 pyranometer uses a state of the art thermopile sensor with black coated surface, two domes and an anodised aluminium body. The connector, desiccant holder and sun screen fixation are ultra robust and designed for industrial use. All parts are specified for use across SR20's entire rated operating temperature range.

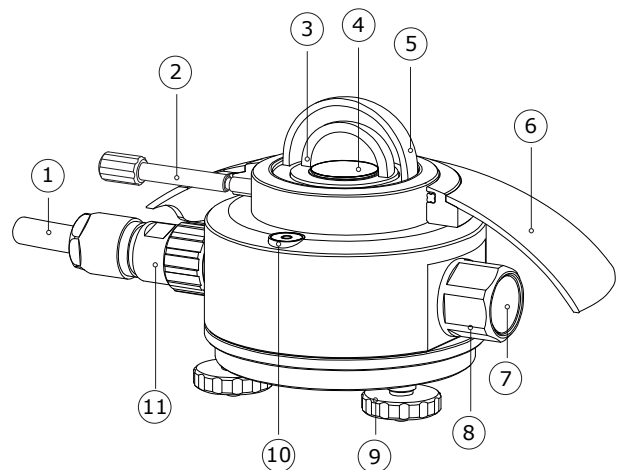

Figure 4 Overview of SR20:

(1) cable, (2) fixation of sun screen, (3) inner dome, (4) thermal sensor with black coating, (5) outer dome, (6) sun screen, (7) humidity indicator, (8) desiccant holder, (9) levelling feet, (10) bubble level, (11) connector.



Figure 5 SR20 with its sun screen removed.

Standards

Applicable instrument classification standards are ISO 9060 and WMO-No. 8. Included in delivery as required by ISO 9060:2018 test certificates for temperature response and directional response. Calibration is according to ISO 9847. PV related standards are IEC 61724 and ASTM E2848.

Choosing the right instrument

Pyranometers are subject to classification in three classes according to ISO 9060.

From Class C to Class B and from Class B to Class A, the achievable accuracy improves by a factor 2.

Measurement accuracy does not only depend on instrument properties, but also on measurement conditions. A very accurate instrument will quickly underperform without a regular schedule of maintenance.

Our [pyranometer selection guide](#) assists you in choosing the right instrument.

Whatever your application is: Hukseflux offers the highest accuracy in every class at the most attractive price level.

Suggested use

- PV system performance monitoring
- scientific meteorological observations



Figure 6 SR20 side view.

See also

- [SR30](#) digital spectrally flat Class A pyranometer with heating and tilt sensor
- [SR20-D2](#) digital spectrally flat Class A pyranometer with Modbus RTU and 4-20 mA output
- alternative instruments: [SR15](#) and [SR05](#) series for lower accuracy measurements
- [PMF01](#) and [PMF02](#) pyranometer mounting fixtures, also for POA (Plane of Array)
- the making of SR20 [documented](#)
- view our complete [product range of solar sensors](#)

SR20 specifications

| | |
|----------------------------------------------------|--------------------------------------------------------------------------------------------------------|
| Measurand | hemispherical solar radiation |
| ISO classification ISO 9060:2018 | spectrally flat Class A pyranometer |
| WMO performance level IEC 61724-1 compliance | high quality pyranometer meets Class A PV monitoring system requirements |
| Calibration uncertainty | < 1.2 % (k = 2) |
| Zero offset a | < 5 W/m ² unventilated |
| Zero offset a | 2.5 W/m ² ventilated |
| Calibration traceability | to WRR |
| Spectral range | 285 to 3000 × 10 ⁻⁹ m |
| Sensitivity (nominal) | 15 × 10 ⁻⁶ V/(W/m ²) |
| Rated operating temperature range | -40 to +80 °C |
| Temperature response | < ± 1 % (-10 to +40 °C) < ± 0.4 % (-30 to +50 °C) with correction in dataprocessing report included |
| Temperature response test of individual instrument | report included to 95 ° |
| Directional response test of individual instrument | report included to 95 ° |
| Temperature sensor | Pt100 or 10 kΩ thermistor |
| Heater | 1.5 W at 12 VDC |
| Standard cable length | 5 m |

Options

- longer cable, in multiples of 5 metres
- ventilated with [VU01](#) ventilation unit

About Hukseflux

Hukseflux is the leading expert in measurement of energy transfer. We design and manufacture sensors and measuring systems that support the energy transition. We are market leaders in solar radiation- and heat flux measurement.

Customers are served through the main office in the Netherlands, and locally owned representations in the USA, Brazil, India, China, Southeast Asia and Japan.

Interested in this product?
E-mail us at: info@hukseflux.com

SR20 analogue Class A pyranometer

This overview summarises the main features and benefits of SR20. Customers prefer Hukseflux pyranometers for their unsurpassed measurement accuracy and their lowest total cost of ownership.



Best measurement accuracy

- spectrally flat
- low zero offsets
- low calibration uncertainty
- best temperature dependence
- heated: compliant with IEC 61724-1 Class A

Lowest total cost of ownership

- efficient worldwide calibration support
- ISO/IEC 17025 calibration available
- fast servicing organisation



Best connector

- interchangeable cables
- IP67 grade
- for industrial use

Best desiccant cartridge

- visible indicator of instrument health
- rugged aluminium design
- serviceable by user

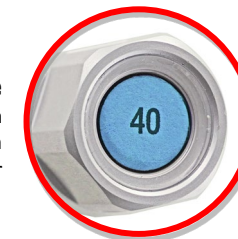

Best sun screen

- sealed
- corrosion protection of body
- no dry-cooking of bubble level

Best humidity protection

- wrench-operated
- o-ring compressed to spec
- desiccant service interval > 2 years

