

# TCOMSYS01 Hot Cube

Thermal comfort measuring system - a new tool for research and education

*TCOMSYS01 is a measuring system to help understand and quantify "causes and effect" leading to human thermal comfort. The TCOM01 body is temperature stabilised at 33 °C, so that it offers a relatively direct measurement of the human experience. In essence, TCOM01 is a miniature thermal mannequin, measuring according to the innovative Hot Cube method. The heater power required to keep the TCOM01 at a constant temperature is the main measurand. Incorporating 5 heat flux sensors with a black absorber, it also offers a detailed picture of the heat gain and loss from different directions, and a good indication of convective and radiative asymmetry. Other measurements are sensor body temperature, air temperature and relative humidity. In its standard configuration, the system consists of an MCU (Measurement and Control Unit) and a TCOM01 sensor. The MCU offers direct connection to any local area network and "Ethernet over USB". TCOM01 is also available as a sensor only.*



**Figure 1** the TCOM01 sensor body on a tripod. The TCOM01 is meant for surveys of thermal comfort as experienced by the human body. It is equipped with 5 x heat flux sensor (black surfaces) and a sensor body temperature sensor. Heater power, ambient temperature and relative humidity are measured in the accompanying MCU (Measurement and Control Unit)



**Figure 2** a complete system for measuring thermal comfort

## Introduction

TCOMSYS01 was originally designed to study the effect of radiation sources on human comfort. Equipped with heat flux sensors that measure in 5 directions and a humidity and temperature probe, it offers a good picture of energy gains and losses from all sides to a metal body that thermally resembles the human body; the TCOM01 sensor is in essence a miniature thermal mannequin.

The TCOMSYS01 system employs dedicated sensors and electronics, measuring thermal comfort according to the new Hot Cube method. The high accuracy of the MCU (Measurement and Control Unit) ensures that TCOMSYS01 will still measure down to very low heat fluxes. The MCU has a robust aluminium housing. The system generates a measurement file, including a time-stamp. The measurement data are stored in the MCU and are later downloaded to a PC. The user is responsible for data analysis.

## TCOMSYS01 advantages

- direct representation of the human body
- helps understand and quantify the detailed physical cause and effect of thermal comfort
- simple experiments can be used to quantify the sources of heat gain or loss
- offers directional information
- good addition to Wet-Bulb Globe temperature measurement
- robust, student-proof
- "stand alone"; equipped with its own clock and memory
- safe, low voltage power supply
- communication by (virtual) Ethernet link
- user interface program on MCU

## How to employ TCOMSYS01

The primary source of information from TCOMSYS01 simply is the power [W] required to keep the TCOM01 sensor at a constant temperature; a very direct measure of human comfort. This power may be compared to the power required at 20 °C ambient air temperature, no convection (zero wind speed) and no radiation. Power consumption will immediately show if there is a situation of overheating or heatstress or a situation of overcooling or coldstress.

The second direct information supplied by the heat flux sensors of TCOMSYS01 is the heat loss or gain [W/m<sup>2</sup>] as a function of direction. If radiative sources are dominant, TCOMSYS01 will measure radiative asymmetry.

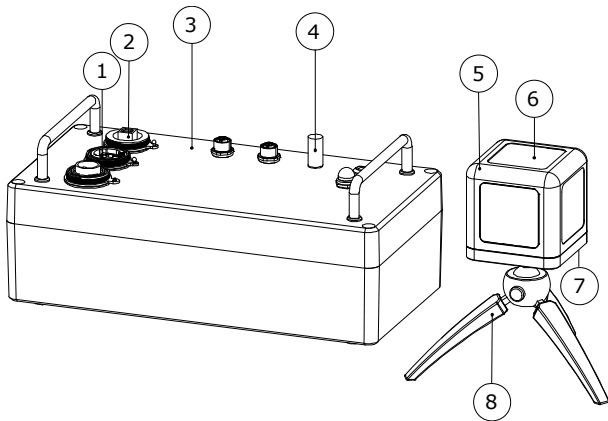

**Figure 3** overview of TCOMSYS01: (1) Ethernet port, (2) USB port, (3) MCU Measurement and Control Unit, (4) air temperature and relative humidity sensor, (5) TCOM01, (6) side panel: heat flux sensor with black absorber foil, (7) connectors (not visible), (8) tripod



**Figure 4** TCOM01 applied in car passenger comfort testing

## TCOMSYS01 specifications

Measurand	heating power for stabilisation
Measurand	heat flux (5 x)
Measurand	ambient air temperature
Measurand	relative humidity
Measurand	TCOM01 body temperature
TCOM01 temperature setting	33 °C (user adjustable)
Included cable	2 x cable with 2 connectors (1.5 m) +10 to +25 °C
Standard rated operating temperature range	- 25 to +50 °C
Limiting temperature range	- 25 to +50 °C
Required data analysis	to be performed by the user
Data display	in web browser
Start up interval	< 10 min

## TCOM01 specifications

Weight	1.12 kg
Temperature sensor	10 kΩ thermistor
IP protection class	IP65
Mounting	tripod with ¼ inch - 20 UNC screw a Manfrotto Pixi EVO 2-section tripod is included

## MCU specifications

User interface	on MCU as a web page
Connection	via LAN or "Ethernet over USB"
Voltage measurement accuracy	4 x 10 <sup>-6</sup> V (0.8 W/m <sup>2</sup> )
Rated power supply voltage	10 to 16 VDC
Adapter power supply	100 – 240 VAC 50/60 Hz
Rated operating temperature range MCU	- 25 to +50 °C
Data storage capacity	2 GB; > 1 year of data

A web browser may be used for real time measurement review, data collection and for changing control settings such as TCOM01 body temperature.

## Suggested use

- surveys of human thermal comfort
- studies of the effect of radiating sources
- workplace investigations
- car passenger comfort testing
- educational purposes, illustrating heat transfer
- bio-meteorology
- microclimate studies
- wind-chill analysis
- analysis of fabric insulation



**Figure 5** TCOMSYS01 with its TCOM01 sensor, tripod, MCU and carrying case

## History

Already in 1929 the Eupatheoscope (from Greek “wellbeing–emotion–examination”) was designed by A.F. Dufton to quantify the condition in a room from the point of view of comfort. It consists of a blackened cylinder which is controlled to maintain a temperature of 23 °C. The power used is interpreted in terms of equivalent temperatures.

In the 1990 the company Bruel & Kjaer carried a thermal comfort meter (model 1212), based on the same principle, and in addition processing Fangers equation.

Both models involved only an integrated power measurement. The new Hot Cube method improves on this by incorporating omnidirectional heat flux measurements.

## What makes TCOMSYS01 different

The main contributors to thermal comfort are air temperature, air speed, radiant temperature and humidity. Apart from this, there are personal contributors such as metabolic rate and insulation by clothing.

Many studies use Fanger’s thermal comfort equation as applied in EN ISO 7730: *Moderate Thermal Environments - Determination of the PMV and PPD indices and specification of the condition for thermal comfort*. Another approach utilises a globe temperature measurement: EN ISO 27243: *Hot environments. Estimation of the heat stress on working man, based on the WBGT Index (Wet Bulb Globe Temperature)*.

These methods are quite indirect in particular when determining the heat flow from air speed and radiation.

- TCOMSYS01 offers heat flux measurements. This approach is a lot more direct than the indirect estimate from air speed and radiation.
- TCOMSYS01 offers directional information.
- TCOMSYS01 works at a realistic skin temperature of 33 °C (user adjustable).

## Rated operating conditions

TCOMSYS01 is designed to work between +10 and +25 °C. In its standard configuration, uninsulated and stabilised at 33 °C, it is rated for operation in indoor conditions including significant radiative heating.

It will stabilise at 33 °C under approximately one of the following conditions:

- air speeds < 5 m/s
- irradiance < 400 W/m<sup>2</sup>
- ambient air temperature > 5 °C

Under other conditions, the sensor may not be able to stabilise its body temperature due to overheating (indicating overheating or heatstress) or shortage of electrical power (indication of overcooling or coldstress). Powered using a low voltage, TCOMSYS01 is safe to use.

TCOMSYS01 may be used for short-term outdoor experiments in the order of weeks. Under long-term exposure to solar radiation, the black heat flux sensor coating may become more reflective.

## User interface: MCU is a web server

The MCU serves as a web server, and can be connected to any local area network. No more downloading of USB drivers and special interface software! Alternatively it offers an “Ethernet over USB” or virtual Ethernet link, where you connect to the MCU using a USB cable. If you type into your web browser the MCU’s IP address (192.168.66.1 by default), you have access to the user interface.

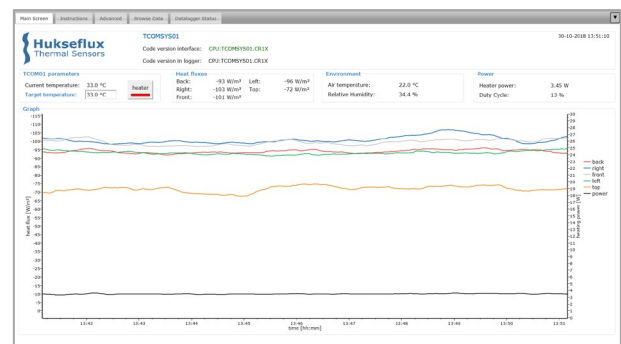

**Figure 6** TCOMSYS01’s user interface: the main screen shows live data, and a graph of the last 10 minutes

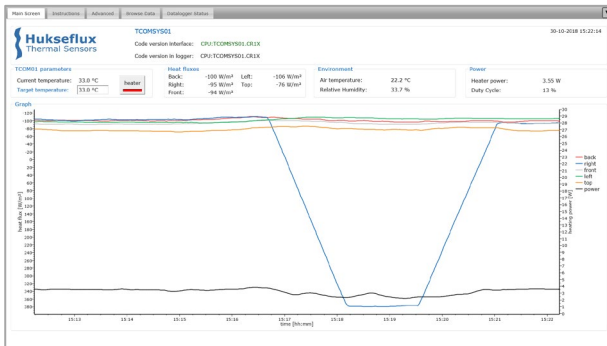

**Figure 7** Example of TCOMSYS01 measurement. Five heat flux signals in  $[W/m^2]$  on the vertical axis, time  $[hr:min:s]$  on the horizontal axis. One side of TCOM01 is exposed to a strong radiative source. The system shows the radiative asymmetry



**Figure 8** TCOM01 is also available as a "sensor only"

## Ordering the TCOM01 sensor only

The sensor TCOM01 is also available as a "sensor only". The configuration then includes the mannequin with 5 x heat flux, 1 x temperature, 1 x heater, 2 x cable, 2 x chassis connector and 1 x tripod. The user then must combine it with his or her own measurement and control unit.

## Options

- TCOM01 sensor only
- extended rated operating conditions; temperature, irradiance, wind speed

## See also

- our complete [product range of heat flux sensors](#)
- view the [TRSYS01](#) building thermal resistance measuring system which includes 2 x HFP01 sensor and 4 x matched thermocouple type K

## About Hukseflux

Hukseflux Thermal Sensors offers measurement solutions for the most challenging applications. We design and supply sensors as well as test & measuring systems, and offer related services such as calibration, engineering and consultancy. Our main area of expertise is measurement of heat transfer and thermal quantities such as solar radiation, heat flux and thermal conductivity. Hukseflux is ISO 9001 certified. Hukseflux sensors, systems and services are offered worldwide via our office in Delft, the Netherlands and local distributors.

Interested in this product?  
E-mail us at: [info@hukseflux.com](mailto:info@hukseflux.com)